



# TCC-1655HC

## 65" Hot Roll Laminator



## OPERATING MANUAL

### **IMPORTANT !!!**

It will be beneficial to first get yourself acquainted with the features of your TCC-1655HC before attempting to use. Keep in mind all operational instructions, tips, and safety reminders every time you use your machine to best achieve desirable results.

**TABLE OF CONTENTS**

**FEATURES AND SAFETY INSTRUCTIONS**

Introduction.....3  
Safety Precautions .....3  
Installation .....3  
Specifications .....4  
Product Identification .....4

**OPERATION**

Control Panel.....5  
Machine Operation .....5  
Temperature and Speed Memory Settings .....6  
Roller Tension Settings .....7

**MAINTENANCE, SERVICE AND WARRANTY**

Maintenance.....7  
Troubleshooting .....7  
Warranty Information .....8

## INTRODUCTION

Thank you for choosing TCC-1655HC Laminator. It has been designed and manufactured to provide years of continuous use. For complete operating and maintenance information, please read this manual thoroughly. Upon receipt for the laminator, please inspect the box, machine, and all other contents for shipping damage. Any damage/s should be brought to the immediate attention of the delivery carrier.

## SAFETY PRECAUTIONS



Failure to comply with any of the following safety procedures could result in serious injury. Please read the instructions carefully and keep this manual for future reference.

1. A licensed electrician should install the proper outlet for the wiring of the machine.
2. Ensure that the unit is plugged into a properly grounded outlet with correct voltage.
3. Do not allow articles of clothing (ties, scarves, etc.) near the machine openings as they could get caught by the rollers and pulled inside causing serious personal injury.
4. Keep machine away from anything flammable and install in a dry location.
5. To prevent the possibility of electric shock, do not immerse machine in water or allow liquid to spill inside.
6. Avoid excessive sunlight, humidity and extreme temperatures.
7. Ensure that the machine is turned off, has cooled down and unplugged from the outlet prior to moving or performing repairs.
8. Keep away from children.
9. Do not open the case without being authorized by a technician.
10. Do not attempt to laminate items that exceed total recommended material thickness for the unit.

## INSTALLATION



**WARNING: The laminator should be installed by a trained service technician**

The laminator comes fully assembled, except for the guide table to avoid shipping damage. Upon arrival, thoroughly inspect the unit. It is imperative that any shipping damage is reported and a claim is filed with the delivering carrier immediately upon receipt.

The laminator should be located in an area with adequate work space for feeding graphics and laminating materials. Avoid placing the laminator in a dusty area or near sources of extreme heat or cold. Once the laminator is in the right place, lock the casters into position. Always unlock the casters when moving to a different location.

# SPECIFICATIONS

<b>MODEL</b>	<b>TCC-1655HC</b>
Max. Laminating width	65" / 1650mm
Max. Laminating speed	3mm / mins
Max. Mounting tThickness	1/2" / 12 mm
Heating system	Heating Roller
Number of Rollers	4
Temperature control	Yes
Speed control	Yes
Display	LCD
Warm-up Time	30 mins
Power supply	AC 220 ~ 240 V / 50,60Hz
Power consumption	3100 watts
Film Core Size	1", 2.25", 3" ( All in One )
Dimension (machine only)	76" x 22" x 14" / 1940 x 560 x 350mm
(on stand)	76" x 22" x 47" / 1940 x 560 x 1200mm
Weight	507lbs / 230kgs
Operating temperature	0-160°C / 320°F

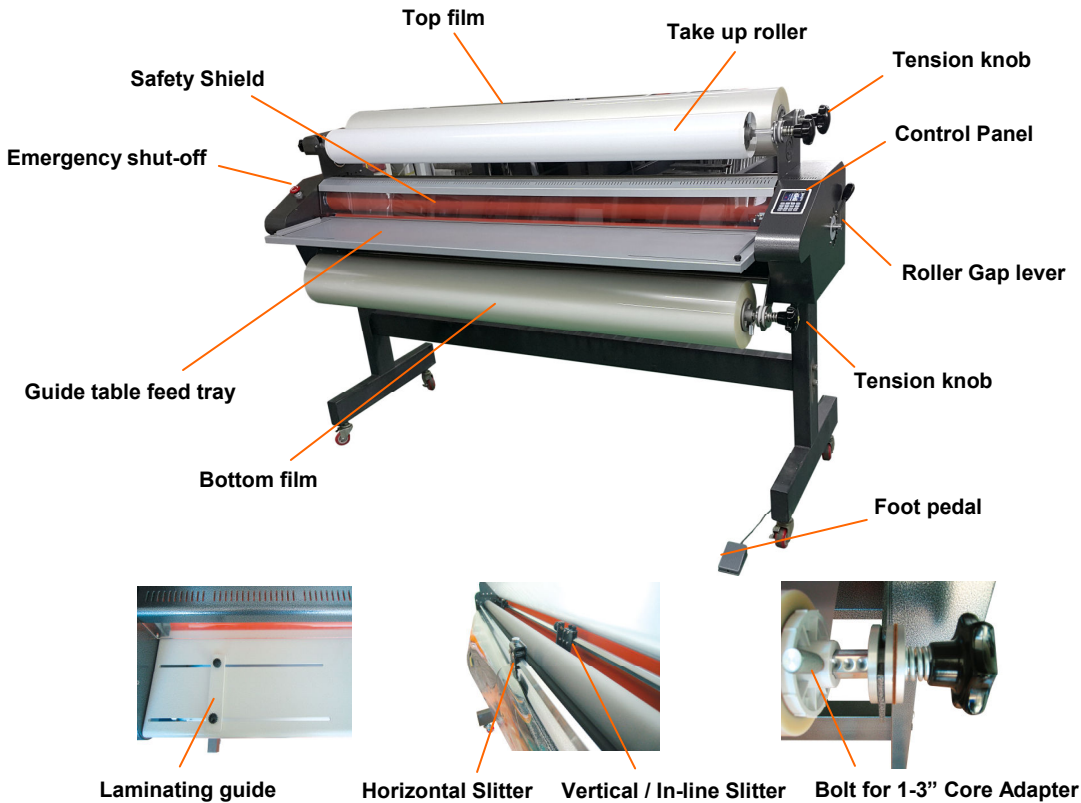

## CONTROL PANEL

When the machine is powered on, the LCD window will display the last working pre-set memory setting.

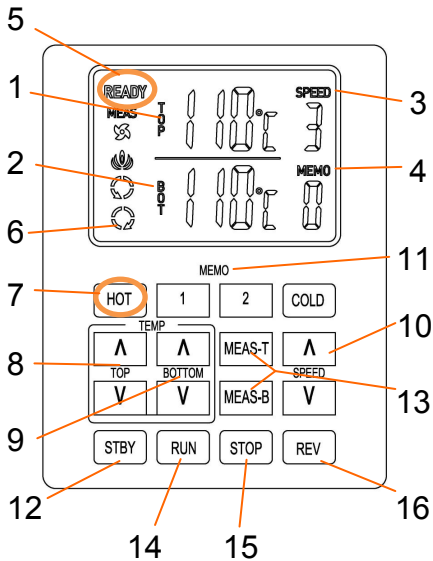

1. TEMP : Top roller temperature  
 2. TEMP : Bottom roller temperature  
 3. SPEED ▲▼ : Variable speed from 1~9.  
 4. MEMORY ▲▼ : Variable memory from 1~2  
 5. READY : When preset temperature is reached  
 6. Rollers are running  
 7. HOT : Machine will initially go to 110°C, speed 3  
 8. TEMP-T ▲▼: Adjust top roller temperature  
 9. TEMP-B ▲▼ : Adjust bottom roller temperature  
 10. SPEED ▲▼ : Variable speed from 1~9.  
 11. M1~M2, COLD : Programming Memory Values:  
 1) Press and hold the button for 1 second;  
 2) Select the temperature and speed;  
 3) Press the button again to save the entry  
 12. STBY : Temperature is set to 85°C  
 13. MEAS-T/B : Measure the actual temperature of top and bottom rollers.  
 14. RUN : Run rollers  
 15. STOP : Stop rollers  
 16. REVERSE : To help clear rollers

## MACHINE OPERATION

1. Install the top and bottom film brackets
2. Load the film with the adhesive side facing the inside of the roll (adhesive in.)

### Hot Lamination

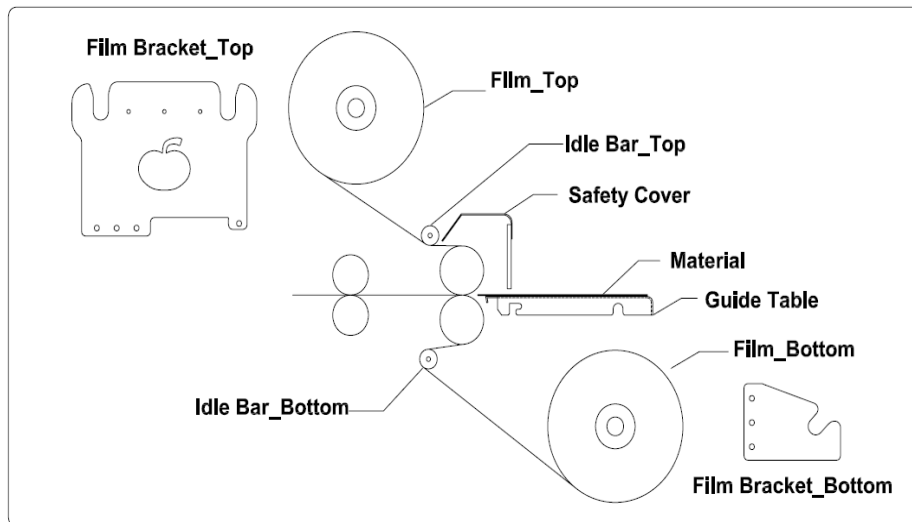

# Cold Lamination

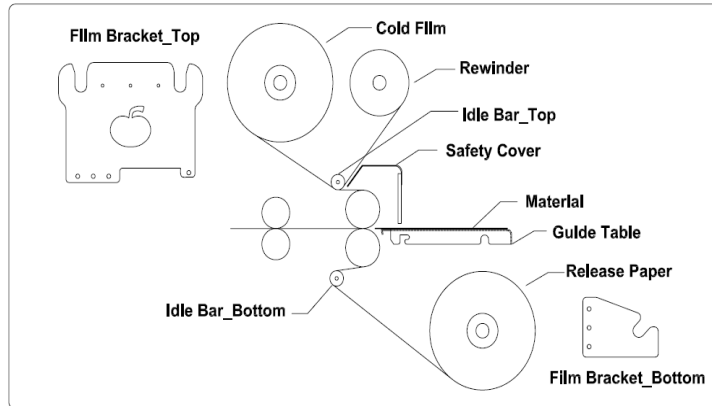

3. Turn the power switch on. It will be located at the back of the machine.
4. Remove the safety shield.
5. Remove the guide table. (see fig. 1)
6. Pull down the top film through the **Idle Bar\_Top** and attach it to the bottom roller. (see fig. 2)
7. Pull up the bottom film through the **Idle Bar\_Bottom** and attach it to the top film of top roller. (see fig. 3)
8. Replace the safety shield and guide plate.
9. Set the temperature and speed.
10. Align the material on the guide table and press the foot pedal.
11. After the laminated material has passed through the rollers, press the foot pedal again to stop.
12. Adjust the roller tension by moving the handle located on the upper side.
13. Carefully pull out the laminating material in the back

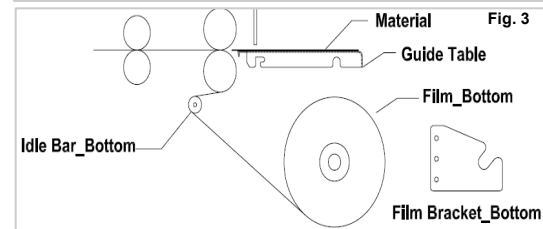
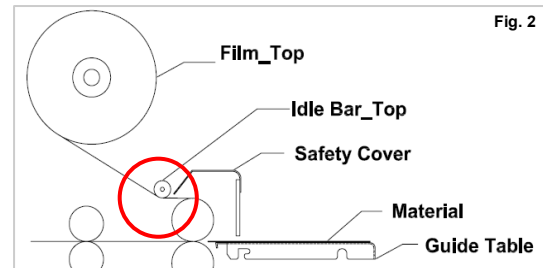
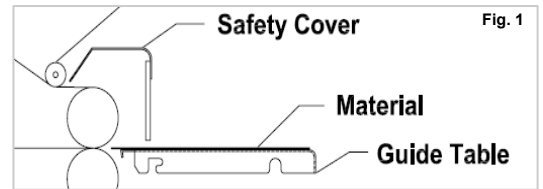

## TEMPERATURE AND SPEED MEMORY SETTINGS

The temperature and speed can be set for your convenience using the memory button. The machine will arrive with settings from factory but the memory values can be changed from M1-M2 and COLD for cold laminating.

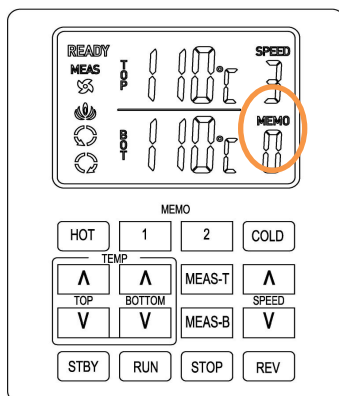

### How to change memory value:

1. Press and hold M1-M2 for 1 second then set-up value.
2. Press up and down for temperature and speed.
3. Press M1-M2 button to save the entry.

### ⚠ ATTENTION

If the machine is left unattended for 1 hour, the temperature will go down to 85°C. You can also do this directly by pressing the StBy button. On the second hour of the machine being left unattended, it will completely turn off automatically.

## ROLLER TENSION SETTINGS

1. Adjust the roller tension to “Laminating” for regular laminating jobs. (2nd to the last slot)
2. When not in use, make sure tension is set at “Standby” or zero tension.

**⚠ IMPORTANT:** The machine has relatively large rollers to help ensure top-quality laminating results therefore it may require some force to move the lever for lamination. To release, push down slightly before pulling it out so that the handle will not “pop out” of the slot.

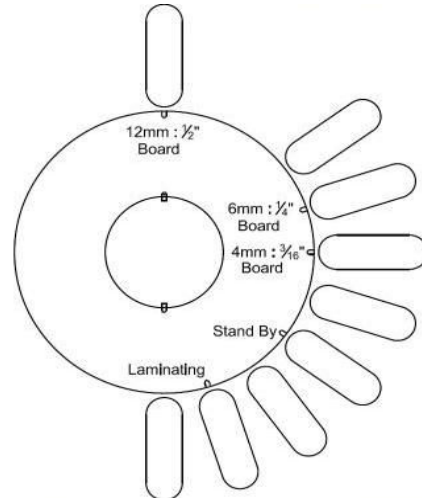

## MAINTENANCE

1. Adjust to the adequate tension setting with the tension knob. If the tension is too tight, the film can get too stretched.
2. Disengage the rollers with Roller Gap Lever and adjust to Standby when not in use. This will help prevent the machine from overheating.
3. Make sure the rollers are always clean. Operating with one roll of laminating film or when the upper and lower film are not properly aligned may leave melted resin on the rollers which may result in poor lamination results. Watch out for dust and any kind of unwanted particles that may affect your lamination..
4. Be sure to turn off the laminator after use.

## TROUBLESHOOTING

Symptom	Cause	Possible solution
Machine will not turn on	a. Power cord is not plugged in.	a. Plug the power cord into appropriate outlet
	b. Pwr switch is in the “off” position.	b. Put the power switch to the "on" position.
	c. Tripped circuit breaker.	c. Reset the circuit breaker.
	d. Blown main power fuse.	d. Replace the fuse.
There is power, but the rollers are not running after the hot button is pressed:	a. Emergency switch is engaged.	a. Disengage the emergency switch.
	b. Safety cover is not closed.	b. Close the safety cover to active the safety switch.
	c. Guide table is not installed correctly.	c. Properly install the paper guide so that the micro switch is activated.
	d. Blown motor fuse.	d. Replace the motor fuse.
The unit is not heating up	a. The machine is in "COLD" mode.	a. Switch to "HOT" mode.
	b. Set temperature is lower than the room temperature.	b. Raise the temperature according to the recommended film temperature.
Curled lamination	a. Upward curl	a. Loosen the top roll film tension.
	b. Downward curl	b. Loosen the bottom roll film tension.
Hazy lamination	a. The main roller temperatures are too low and lamination speed is too fast.	a. Raise the roller temperatures and lower the lamination speed.

## WARRANTY INFORMATION

This machine is guaranteed against defects in materials and workmanship by the Manufacturer for a period of one (1) year from the date of original purchase from an authorized distributor of Tamerica Products, Inc. If you perceive or experience any issue with the machine, kindly report it to the distributor within 10 business days of said purchase to avail of free pickup and redelivery from Tamerica's Service Center. After the first 10 days, you will either receive service instructions and parts via mail free of charge for the duration of the warranty.

Note that when returning the machine for warranty claims, the machine should be returned in its complete original packaging to avoid incidental or consequential damages that may void the claim. A copy of the invoice or other proof of purchase also needs to be sent with the machine.

Upon evaluation of the machine and the determination of the actual defect, the machine will be restored to its regular working condition by the Service Center and shipped back to you free of charge. If you change your mind and simply want to return the machine, a 20% restocking fee is charged even within the 10-day grace period. Further, you will have to cover freight to return the machine and it has to be in brand-new resalable condition, otherwise, you might incur more charges.

**This warranty covers all defects incurred in the normal use of the equipment except in the following cases:**

1. Loss or damage to the equipment due to improper operation, abuse, mishandling or failure to follow the operating instructions.
2. Removal or alteration of the serial number.

The machine being serviced or modified by anyone other than a certified technician authorized by TAMERICA.

This warranty expresses the entire obligation of the Manufacturer. Unless prohibited by law, neither this warranty nor any other warranty expressed or implied, including implied warranties of merchantability, shall extend this warranty period. Again, no responsibility is assured for incidental or consequential damages.

This warranty is valid only in the 48 Contiguous States, Hawaii and Alaska excluded.



